



Winstar Display Co., LTD
華凌光電股份有限公司



WEB: <http://www.winstar.com.tw> E-mail: winstar@winstar.com.tw

SPECIFICATION

CUSTOMER : _____

MODULE NO.: **WF57FTLAFDNN0#**

<p>APPROVED BY: (FOR CUSTOMER USE ONLY)</p>	<p>PCB VERSION: _____ DATA: _____</p>
---	---

SALES BY	APPROVED BY	CHECKED BY	PREPARED BY
			葉虹蘭
ISSUED DATE: 2017/03/29			



RECORDS OF REVISION

DOC. FIRST ISSUE

VERSION	DATE	REVISED PAGE NO.	SUMMARY
0	2016/09/23		First issue
A	2016/10/20		Modify Viewing angle.
B	2017/03/29		Modify LED driving conditions

WINSTAR DISPLAY Co., Ltd.

Contents

1.Module Classification Information

2.Summary

3.General Specification

4.Absolute Maximum Ratings

5.Electrical Characteristics

6.DC Characteristics

7.AC Characteristics

8.Optical Characteristics

9.Interface

10.Block Diagram

11.Reliability

12.Contour Drawing

13.Other

WINSTAR DISPLAY Co., Ltd.

1.Module Classification Information

W F 57 F T L A F D N N 0 #
 ① ② ③ ④ ⑤ ⑥ ⑦ ⑧ ⑨ ⑩ ⑪ ⑫ ⑬

①	Brand : WINSTAR DISPLAY CORPORATION						
②	Display Type : F→TFT Type, J→Custom TFT						
③	Display Size : 5.7" TFT						
④	Model serials no.						
⑤	Backlight Type :	F→CCFL, White S→LED, High Light White			T→LED, White		
⑥	LCD Polarize Type/ Temperature range/ Gray Scale Inversion Direction	C→Transmissive, N. T, 6:00 ; I→Transmissive, W. T, 6:00 F→Transmissive, N.T,12:00 ; L→Transmissive, W.T,12:00 N→Transmissive, Super W.T, 6:00 Q→Transmissive, Super W.T, 12:00 X→Transmissive, W.T, VA TFT V→Transmissive, Super W.T, VA TFT R→Transmissive, Super W.T, O-TFT Z→Transmissive, W.T, O-TFT A→Transmissive, N.T, IPS TFT Y→Transmissive, W.T, IPS TFT					
⑦	A : TFT LCD B : TFT+FR+CONTROL BOARD C : TFT+FR+A/D BOARD D : TFT+FR+A/D BOARD+CONTROL BOARD E : TFT+FR+POWER BOARD F : TFT+CONTROL BOARD			G : TFT+FR H : TFT+D/V BOARD I : TFT+FR+D/V BOARD J : TFT+POWER BD			
⑧	Resolution:						
	A: 128160	B:320234	C:320240	D:480234	E:480272	F: 640480	G: 800480
	H:1024600	I:320480	J:240320	K:800600	L:240400	M :1024768	P :1280800
	S:480128	T:800320					
⑨	D: Digital L : LVDS						
⑩	Interface : N : without control board A : 8Bit B : 16Bit						
⑪	TS : N : Without TS T : resistive touch panel C : capacitive touch panel (G-F-F) G : capacitive touch panel(G-G)						
⑫	Version						
⑬	Special Code	#:Fit in with ROHS directive regulations					

2.Summary

TFT 5.7” is a TN transmissive type color active matrix TFT liquid crystal display that use amorphous silicon TFT as switching devices. This module is a composed of a TFT_LCD module, It is usually designed for industrial application and this module follows RoHs.

WINSTAR DISPLAY Co., Ltd.

3. General Specifications

Item	Dimension	Unit
Size	5.7	inch
Dot Matrix	640 x RGBx480(TFT)	dots
Module dimension	125.0 x 98.8 x 5.95	mm
Active area	115.2 x 86.4	mm
Dot pitch	0.06 x 0.18	mm
LCD type	TFT, Normally White, Transmissive	
View Direction	6 o'clock	
Gray Scale Inversion Direction	12 o'clock	
Aspect Ratio	4:3	
Backlight Type	LED ,Normally White	
With /Without TP	Without TP	
Surface	Glare	

*Color tone slight changed by temperature and driving voltage.

4. Absolute Maximum Ratings

Item	Symbol	Min	Typ	Max	Unit
Operating Temperature	TOP	-20	—	+70	°C
Storage Temperature	TST	-30	—	+80	°C

Note: Device is subject to be damaged permanently if stresses beyond those absolute maximum ratings listed above

1. Temp. $\leq 60^{\circ}\text{C}$, 90% RH MAX. Temp. $> 60^{\circ}\text{C}$, Absolute humidity shall be less than 90% RH at 60°C

WINSTAR DISPLAY Co., Ltd.

5. Electrical Characteristics

5.1. Operating conditions:

Item	Symbol	Condition	Min	Typ	Max	Unit
Supply Voltage For LCM	VCC	—	3.0	3.3	3.6	V
Supply Current For LCM	ICC	-	—	9	—	mA
Power Consumption	-	-	—	29.7	—	mW
Power Supply for Analog	AVDD	AVDD-AGND	10.5		11	V
Input Voltage	VIH	H Level	0.7VCC	—	VCC	V
	VIL	L Level	0	—	0.3VCC	V
Recommended LC Driving Voltage for 25°C	VGH	(Note)	13	16	17	V
	VGL		-8	-7	-6	V
	VCOM		3.97	4.02	4.07	V

Note 1 : This value is test for VDD=3.3V , Ta=25 °C only

- (1) VGH is TFT Gate on operating Voltage.
- (2) VGH is TFT Gate off operating Voltage ,VGL signal must be fluctuates with same phase as VCOM when Storage on Gate structure.
- (3) VCOM must be adjusted to optimize display quality Crosstalk , Contrast Ratio and etc

5.2. LED driving conditions

Parameter	Symbol	Min.	Typ.	Max.	Unit	Remark
LED current	-	-	60	-	mA	-
Power Consumption	-	-	1386	1479	mW	-
LED voltage	VBL+	18.9	23.1	24.5	V	Note 1
LED Life Time	-	-	50,000	-	Hr	Note 2,3,4

Note 1 : There are 1 Groups LED

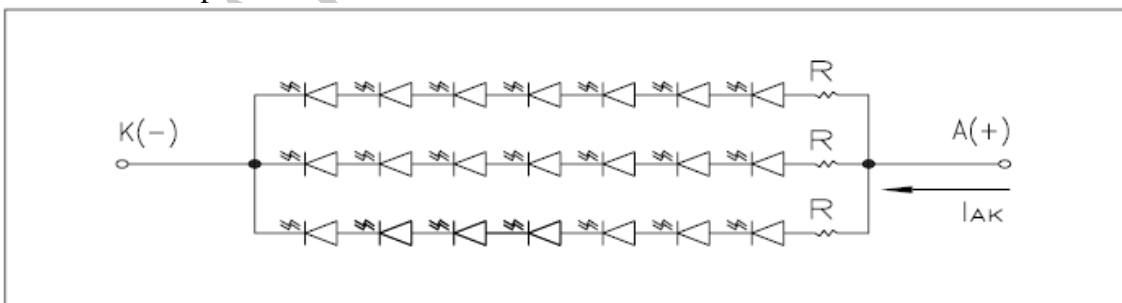

Note 2 : Ta = 25 °C

Note 3 : Brightness to be decreased to 50% of the initial value

Note 4 : The single LED lamp case

6.DC CHARATERISTICS

Parameter	Symbol	Rating			Unit	Condition
		Min	Typ	Max		
Low level input voltage	V_{IL}	0	-	0.3VCC	V	
High level input voltage	V_{IH}	0.7VCC	-	VCC	V	

WINSTAR DISPLAY Co., Ltd.

7. Timing Characteristics

7.1. AC TIMING CHARACTERISTICS

Please refer to the IC SPEC :(Himax) HX8250-A01B
(Himax) HX8678-A000

7.2. POWER ON/OFF SEQUENCE

To prevent the device damage from latch up, the power ON/OFF sequence shown below must be followed.

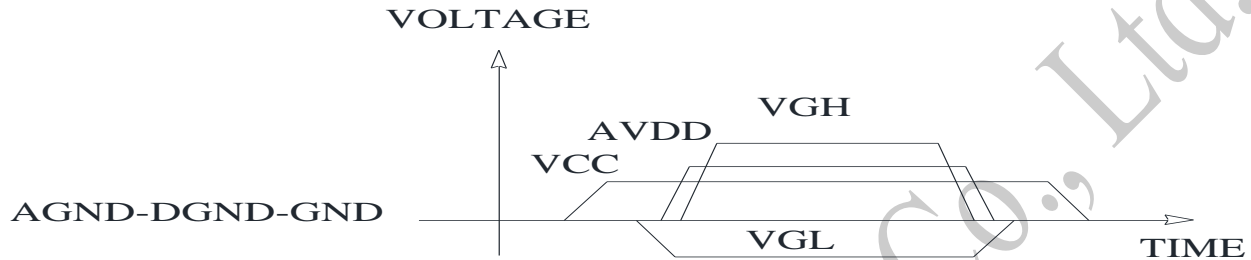

(NOET) DISPLAY DIRECTION OF THE PANEL

The UD and LR control the Display direction of the panel .
The settings of UD and LR are or following:



(1) UD=VCC and LR=DGND



(2) UD=VCC and LR=VCC



(3) UD= DGND and LR=DGND



(4) UD= DGND and LR= VCC

8. Optical Characteristics

Item	Symbol	Condition.	Min	Typ.	Max.	Unit	Remark	
Response time	Tr+ Tf	$\theta=0^\circ \cdot \Phi=0^\circ$	-	15	-	ms	Note 3,5	
			-	35	-			
Contrast ratio	CR	At optimized viewing angle	150	250	-	-	Note 4,5	
Color Chromaticity	White	$\theta=0^\circ \cdot \Phi=0$	Wx	0.28	0.31	0.34	-	Note 2,6,7
			Wy	0.32	0.35	0.38	-	
Viewing angle (Gray Scale Inversion Direction)	Hor.	ΘR	-	60	-	Deg.	Note 1	
		ΘL	-	60	-			
	Ver.	ΦT	-	60	-			
		ΦB	-	40	-			
Brightness	-	-	400	500	-	cd/ m ²	Center of display	

Ta=25±2°C, IL=60mA

Note 1: Definition of viewing angle range

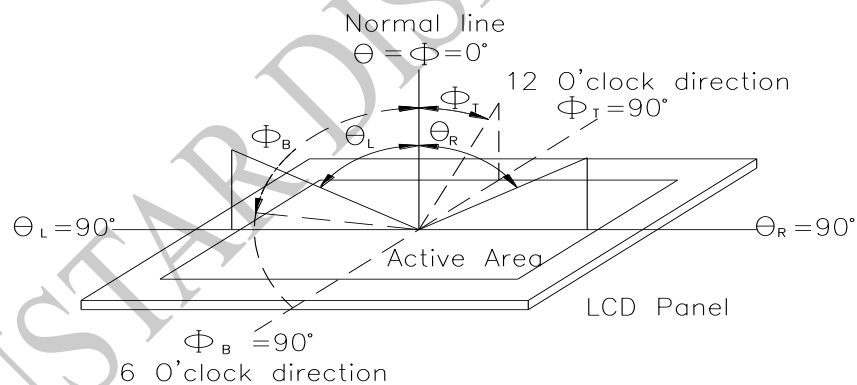

Fig.8.1. Definition of viewing angle

Note 2: Test equipment setup:

After stabilizing and leaving the panel alone at a driven temperature for 10 minutes, the measurement should be executed. Measurement should be executed in a stable, windless, and dark room. Optical specifications are measured by Topcon BM-7 or BM-5 luminance meter 1.0° field of view at a distance of 50cm and normal direction.

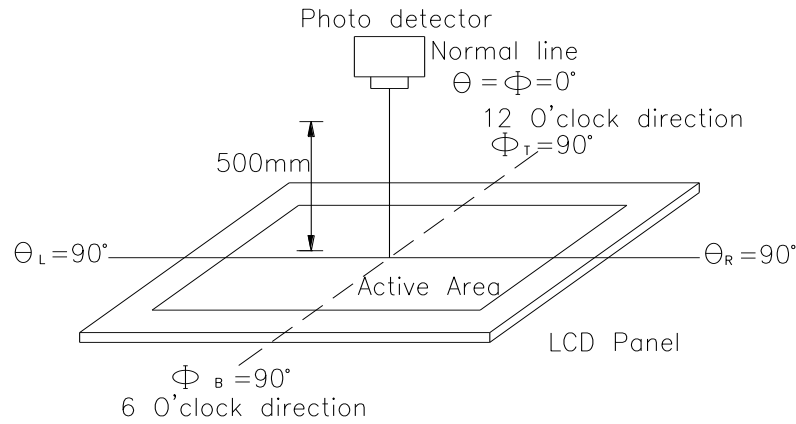
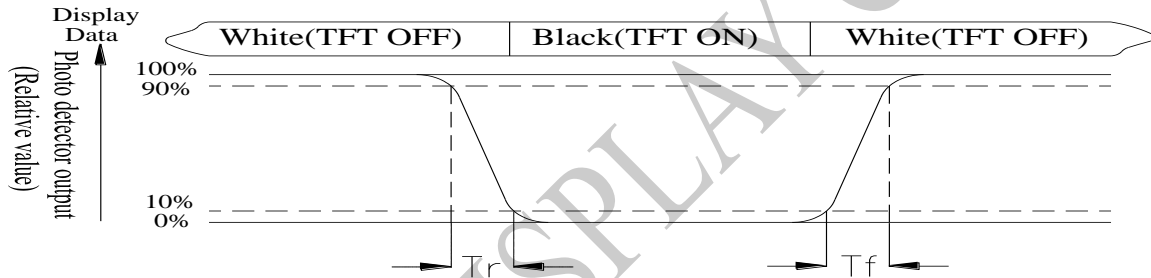

Fig. 8.2. Optical measurement system setup

Note 3: Definition of Response time:

The response time is defined as the LCD optical switching time interval between “White” state and “Black” state. Rise time, T_r , is the time between photo detector output intensity changed from 90% to 10%. And fall time, T_f , is the time between photo detector output intensity changed from 10% to 90%



Note 4: Definition of contrast ratio:

The contrast ratio is defined as the following expression.

$$\text{Contrast ratio (CR)} = \frac{\text{Luminance measured when LCD on the "White" state}}{\text{Luminance measured when LCD on the "Black" state}}$$

Note 5: White $V_i = V_{i50} \pm 1.5V$

Black $V_i = V_{i50} \pm 2.0V$

“±” means that the analog input signal swings in phase with VCOM signal.

“±” means that the analog input signal swings out of phase with VCOM signal.

The 100% transmission is defined as the transmission of LCD panel when all the input terminals of module are electrically opened.

Note 6: Definition of color chromaticity (CIE 1931)

Color coordinates measured at the center point of LCD

Note 7: Measured at the center area of the panel when all the input terminals of LCD panel are electrically opened.

9.Interface

9.1. LCM PIN Definition

Pin	Symbol	Function	Remark
1	DGND	Ground for digital circuit	
2	VCC	Power Supply : +3.3V	
3	VCC	Power Supply : +3.3V	
4	DGND	Ground for digital circuit	
5	VGL	Gate off power	
6	DGND	Ground for digital circuit	
7	VGH	Gate on power	
8	DGND	Ground for digital circuit	
9	UD	Up/down selection	
10	LR	Left /right selection	
11	SPENA	Chip select	
12	SPCK	Serial Clock	
13	SPDA	Serial Data	
14	NC	No connect	
15	DGND	Ground for digital circuit	
16	B5	Blue Data bus	
17	B4	Blue Data bus	
18	B3	Blue Data bus	
19	B2	Blue Data bus	
20	B1	Blue Data bus	
21	B0	Blue Data bus	
22	NC(TOP)	No connection	
23	NC(RIGHT)	No connection	
24	DGND	Ground for digital circuit	
25	G5	Green Data bit	
26	G4	Green Data bit	
27	G3	Green Data bit	
28	G2	Green Data bit	
29	G1	Green Data bit	
30	G0	Green Data bit	
31	NC(BOTTOM)	No connection	
32	NC(LEFT)	No connection	
33	AGND	Ground	

34	AVDD	Analog power: 10V	
35	AVDD	Analog power: 10V	
36	AGND	Ground	
37	R5	Red Data bit	
38	R4	Red Data bit	
39	R3	Red Data bit	
40	R2	Red Data bit	
41	R1	Red Data bit	
42	R0	Red Data bit	
43	DGND	Ground for digital circuit	
44	DGND	Ground for digital circuit	
45	DE	Data Enable input	
46	CLK	Data Clock	
47	HS	Horizontal sync input	
48	VS	Vertical sync input	
49	VCOM	VCOM driving input	
50	DGND	Ground for digital circuit	

9.2. Backlight PIN Definition

Pin No.	Symbol	Description
1	A	Red, LED_ Anode
2	K	Black, LED_ Cathode

10. Block Diagram

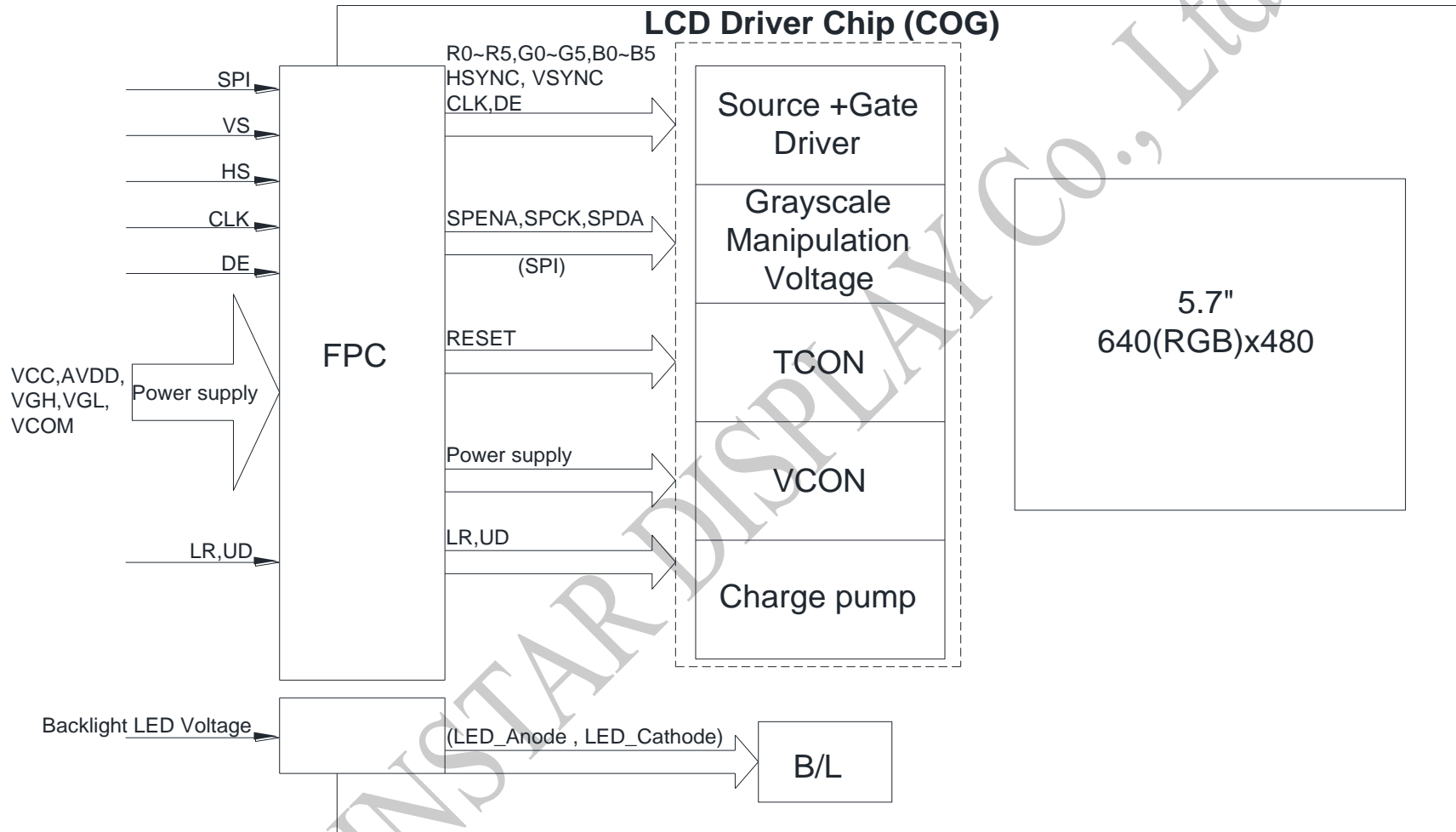

10.1.

11. Reliability

Content of Reliability Test (Wide temperature, -20°C ~70°C)

Environmental Test			
Test Item	Content of Test	Test Condition	Note
High Temperature storage	Endurance test applying the high storage temperature for a long time.	80°C 200hrs	2
Low Temperature storage	Endurance test applying the low storage temperature for a long time.	-30°C 200hrs	1,2
High Temperature Operation	Endurance test applying the electric stress (Voltage & Current) and the thermal stress to the element for a long time.	70°C 200hrs	—
Low Temperature Operation	Endurance test applying the electric stress under low temperature for a long time.	-20°C 200hrs	1
High Temperature/ Humidity Operation	The module should be allowed to stand at 60 °C, 90%RH max	60°C, 90%RH 96hrs	1,2
Thermal shock resistance	The sample should be allowed stand the following 10 cycles of operation <div style="text-align: center;"> <p style="text-align: center;">-20°C 25°C 70°C</p> <p style="text-align: center;">30min 5min 30min</p> <p style="text-align: center;">1 cycle</p> </div>	-20°C/70°C 10 cycles	—
Vibration test	Endurance test applying the vibration during transportation and using.	Total fixed amplitude : 1.5mm Vibration Frequency : 10~55Hz One cycle 60 seconds to 3 directions of X, Y, Z for Each 15 minutes	3
Static electricity test	Endurance test applying the electric stress to the terminal.	VS=±600V(contact), ±800v(air), RS=330Ω CS=150pF 10 times	—

Note1: No dew condensation to be observed.

Note2: The function test shall be conducted after 4 hours storage at the normal Temperature and humidity after remove from the test chamber.

Note3: The packing have to including into the vibration testing.

12. Contour Drawing

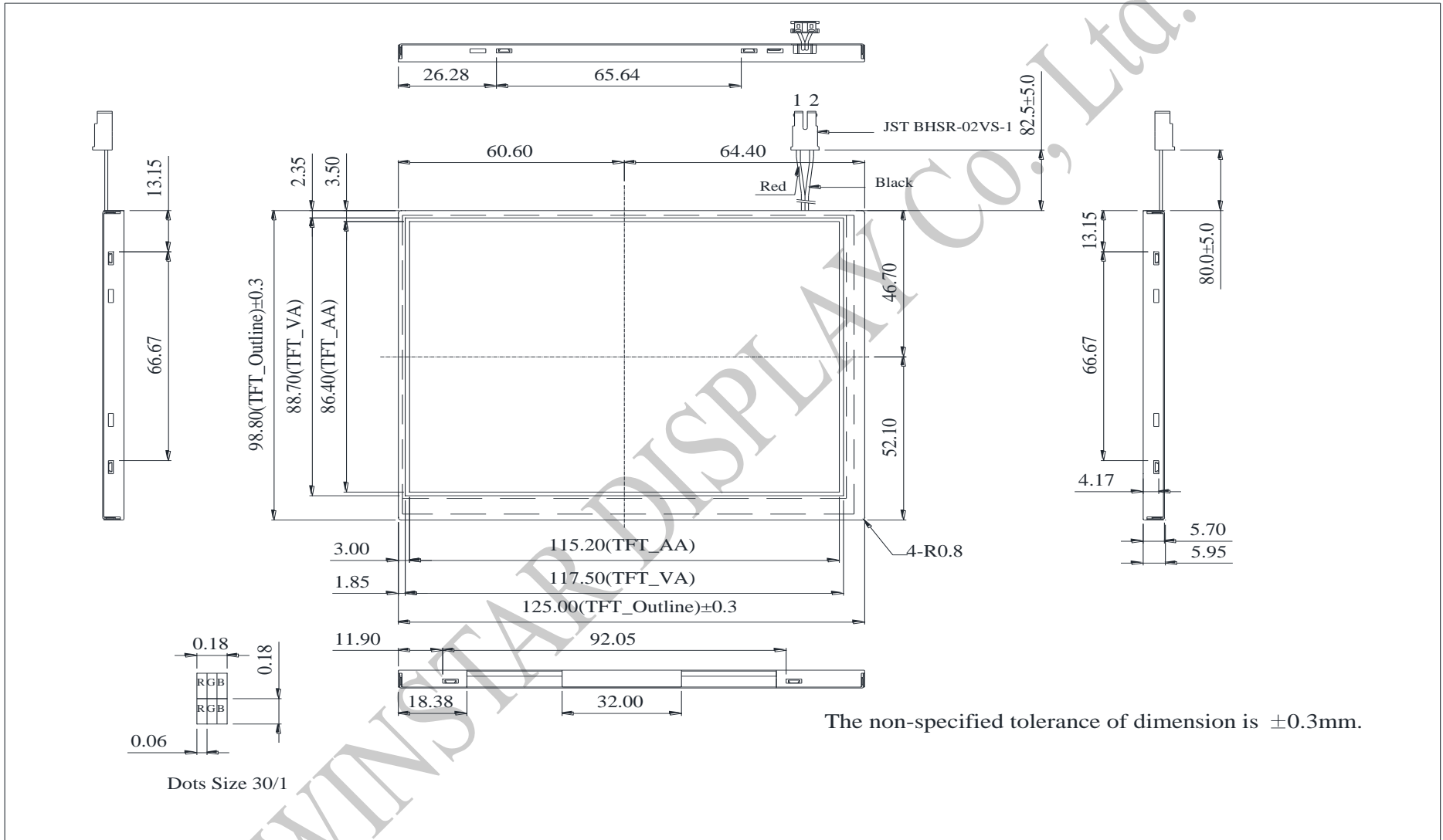

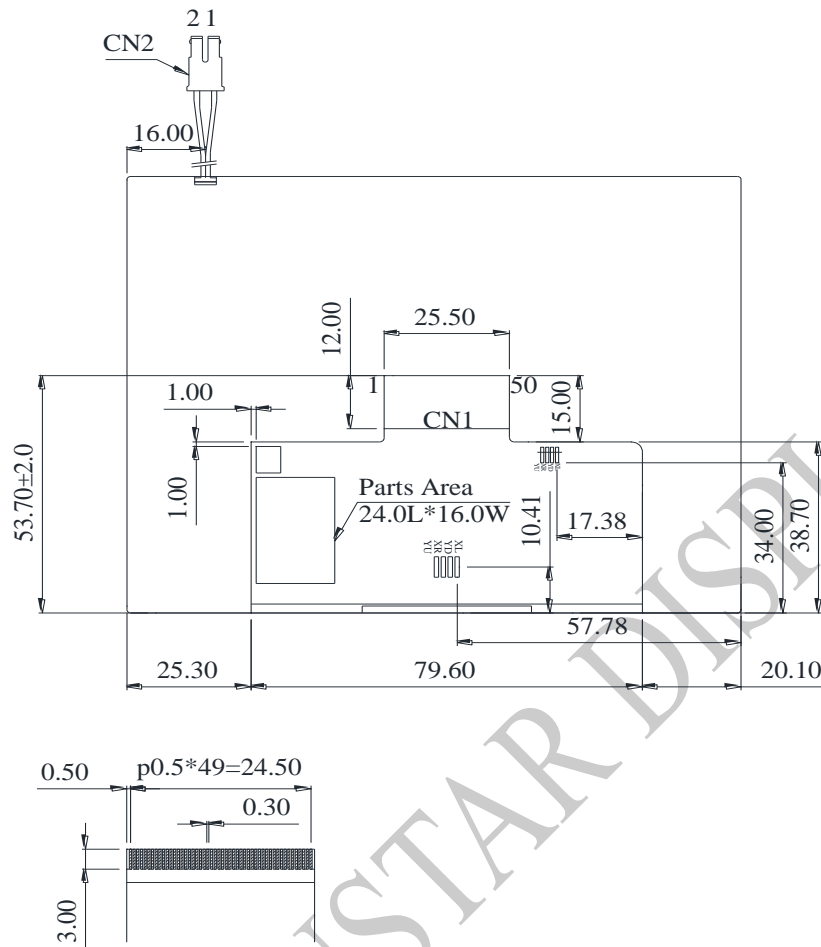

CN2

PIN NO.	SYMBOL
1	A
2	K

CN1

PIN NO.	SYMBOL	PIN NO.	SYMBOL
1	DGND	26	G4
2	VCC	27	G3
3	VCC	28	G2
4	DGND	29	G1
5	VGL	30	G0
6	DGND	31	NC(BOTTOM)
7	VGH	32	NC(LEFT)
8	DGND	33	AGND
9	UD	34	AVDD
10	LR	35	AVDD
11	SPENA	36	AGND
12	SPCK	37	R5
13	SPDA	38	R4
14	NC	39	R3
15	DGND	40	R2
16	B5	41	R1
17	B4	42	R0
18	B3	43	DGND
19	B2	44	DGND
20	B1	45	DE
21	B0	46	CLK
22	NC(TOP)	47	HS
23	NC(RIGHT)	48	VS
24	DGND	49	VCOM
25	G5	50	DGND

The non-specified tolerance of dimension is $\pm 0.3\text{mm}$.



1、Panel Specification :

- 1. Panel Type : Pass NG , _____
- 2. View Direction : Pass NG , _____
- 3. Numbers of Dots : Pass NG , _____
- 4. View Area : Pass NG , _____
- 5. Active Area : Pass NG , _____
- 6. Operating : Pass NG , _____
- 7. Storage Temperature : Pass NG , _____
- 8. Others : _____

2、Mechanical

- 1. PCB Size : Pass NG , _____
- 2. Frame Size : Pass NG , _____
- 3. Material of Frame : Pass NG , _____
- 4. Connector Position : Pass NG , _____
- 5. Fix Hole Position : Pass NG , _____
- 6. Backlight Position : Pass NG , _____
- 7. Thickness of PCB : Pass NG , _____
- 8. Height of Frame to PCB : Pass NG , _____
- 9. Height of Module : Pass NG , _____
- 10. Others : Pass NG , _____

3、Relative Hole Size :

- 1. Pitch of Connector : Pass NG , _____
- 2. Hole size of Connector : Pass NG , _____
- 3. Mounting Hole size : Pass NG , _____
- 4. Mounting Hole Type : Pass NG , _____
- 5. Others : Pass NG , _____

4、Backlight Specification :

- 1. B/L Type : Pass NG , _____
- 2. B/L Color : Pass NG , _____
- 3. B/L Driving Voltage (Reference for LED) : Pass NG , _____
- 4. B/L Driving Current : Pass NG , _____
- 5. Brightness of B/L : Pass NG , _____
- 6. B/L Solder Method : Pass NG , _____
- 7. Others : Pass NG , _____



Winstar Module Number : _____

Page: 2

5、Electronic Characteristics of Module :

- 1. Input Voltage : Pass NG , _____
- 2. Supply Current : Pass NG , _____
- 3. Driving Voltage for LCD : Pass NG , _____
- 4. Contrast for LCD : Pass NG , _____
- 5. B/L Driving Method : Pass NG , _____
- 6. Negative Voltage Output : Pass NG , _____
- 7. Interface Function : Pass NG , _____
- 8. LCD Uniformity : Pass NG , _____
- 9. ESD test : Pass NG , _____
- 10. Others : Pass NG , _____

6、Summary :

Sales signature : _____

Customer Signature : _____

Date : / / _____

